

MFJ

MFJ Antenna Bridge

Model MFJ-204B

INSTRUCTION MANUAL



CAUTION: Read All Instructions Before Operating Equipment

MFJ ENTERPRISES, INC.

300 Industrial Park Road
Starkville, MS 39759 USA
Tel: 662-323-5869 Fax: 662-323-6551

DISCLAIMER

Information in this manual is designed for **user purposes only** and is *not* intended to supersede information contained in customer regulations, technical manuals/documents, positional handbooks, or other official publications. The copy of this manual provided to the customer will *not* be updated to reflect current data.

Customers using this manual should report errors or omissions, recommendations for improvements, or other comments to MFJ Enterprises, 300 Industrial Park Road, Starkville, MS 39759. Phone: (662) 323-5869; FAX: (662) 323-6551. Business hours: M-F 8-4:30 CST.

Table of Contents

<u>TOPIC</u>	<u>PAGE</u>
1. TABLE OF CONTENTS	2
2. LIST OF FIGURES AND TABLES	2
3. INTRODUCTION AND FEATURES	3
4. USES FOR THE MFJ-204B	4
5. SYSTEM CONTROLS AND INDICATORS	5
6. THEORY OF OPERATION	7
7. MFJ-204B EASY-START INSTRUCTIONS	8
8. IN CASE OF DIFFICULTY	13
9. TECHNICAL ASSISTANCE	13
 <u>APPENDICES</u>	
A. Zero Beating Against a Receiver	12
 <u>LIST OF FIGURES</u>	
Figure 1 Front Panel Jacks and Controls	5
Figure 2 End Panel Jacks	6
Figure 3 Block Diagram	7
Figure 4 MFJ-204B to Tuner Hook Up	9
Figure 5 Schematic Diagram	11

INTRODUCTION:

The MFJ-204B gives you a direct readout of your antenna's SWR without the need for formulas or indirect readings. The MFJ-204B can also be used to adjust a tuner to match your antenna without the need for transmitting. The frequency coverage for the MFJ-204B is from below 1.75 MHZ to Above 30 MHZ in 5 user selectable bands.

FEATURES

Portable – The MFJ-204B's light weight, small size and internal battery capability makes it great for Field Day, Travel or any time you need to check out a new antenna installation quickly easily.

Great Value – The MFJ-204B's low cost puts a great instrument in your hands for those who only need to adjust their antennas occasionally.

Stable – With built in AGC the MFJ-204B is accurate across the bands. No false readings.

Wide Range – Determine the RF Resistance of your antenna from 10 to over 600 ohms.

Rugged Construction: Attractive all-metal cabinet, conservative component selection and extensive RF filtering ensure solid performance for years to come. Fully covered by MFJ's "No Matter What" one year limited warranty.

Before attempting to operate your MFJ-204B, please read the manual thoroughly. It contains important detail about setting up your unit to obtain the best performance.

USES

Your MFJ-204B ANTENNA BRIDGE has many uses. It can be used to find the resonant frequency of your antenna, to find the SWR of your antenna at a particular frequency, and to find the frequency at which your antenna has the lowest SWR. You can also use the Antenna Bridge to adjust your antenna to a low SWR and to adjust an antenna tuner to match the transmitter to your transmission line. You can even find out if your antenna is resonant on more than one frequency.

The added benefit of using an Antenna Bridge over a SWR meter is that you can adjust antennas to impedances other than 50 Ohms. This is handy if you are using CATV hardline, Ladder line or any other non 50 ohm coax.

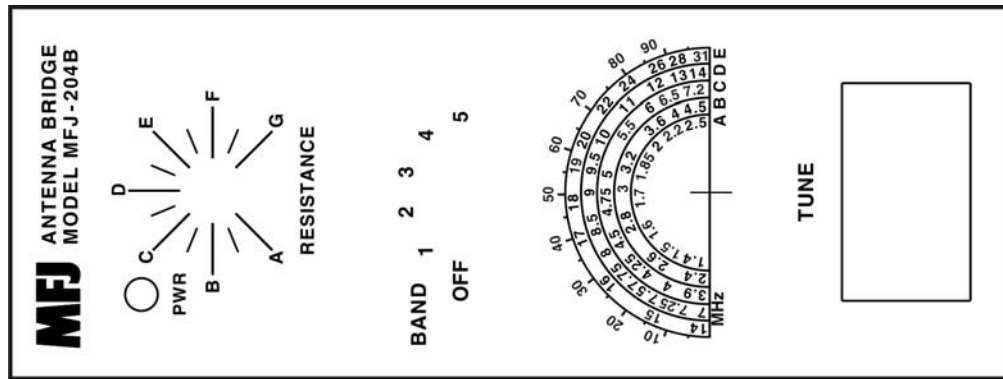

FIGURE 1: Front Panel Jacks and Controls

1. **Power On LED:** Instantly know if the MFJ-204B is on or off with this bright LED.
2. **Resistance Scale:** This is where you read the resistance of your antenna using the calibration chart for your unit.
3. **Band Select Switch:** This 6 position switch turn the power on and selects any one of five over lapping bands.
4. **Tune Control:** This variable capacitor instantly sweeps across the desired band to find that SWR fast and easy.
5. **Null Meter:** Instantly determine the null point of the RF Bridge.

Frequency Coverage of the Bands

NOTE: The frequency coverage may vary slightly from this chart and the label on the cover of the unit and is for reference only. A frequency counter can be connected to the Freq. Out connector shown in Figure 2 to get a more accurate reading of the frequency. As an alternative to a frequency counter you can Zero Beat the output with an HF receiver. See Appendix A.

BAND A:	1.40	-	2.50	MHz
BAND B:	2.40	-	4.50	MHz
BAND C:	3.90	-	7.20	MHz
BAND D:	7.00	-	14.00	MHz
BAND E:	14.00	-	31.00	MHz

End Panel Jacks

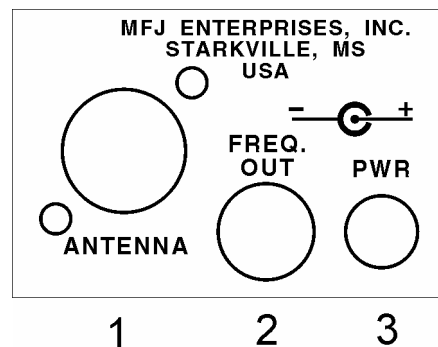
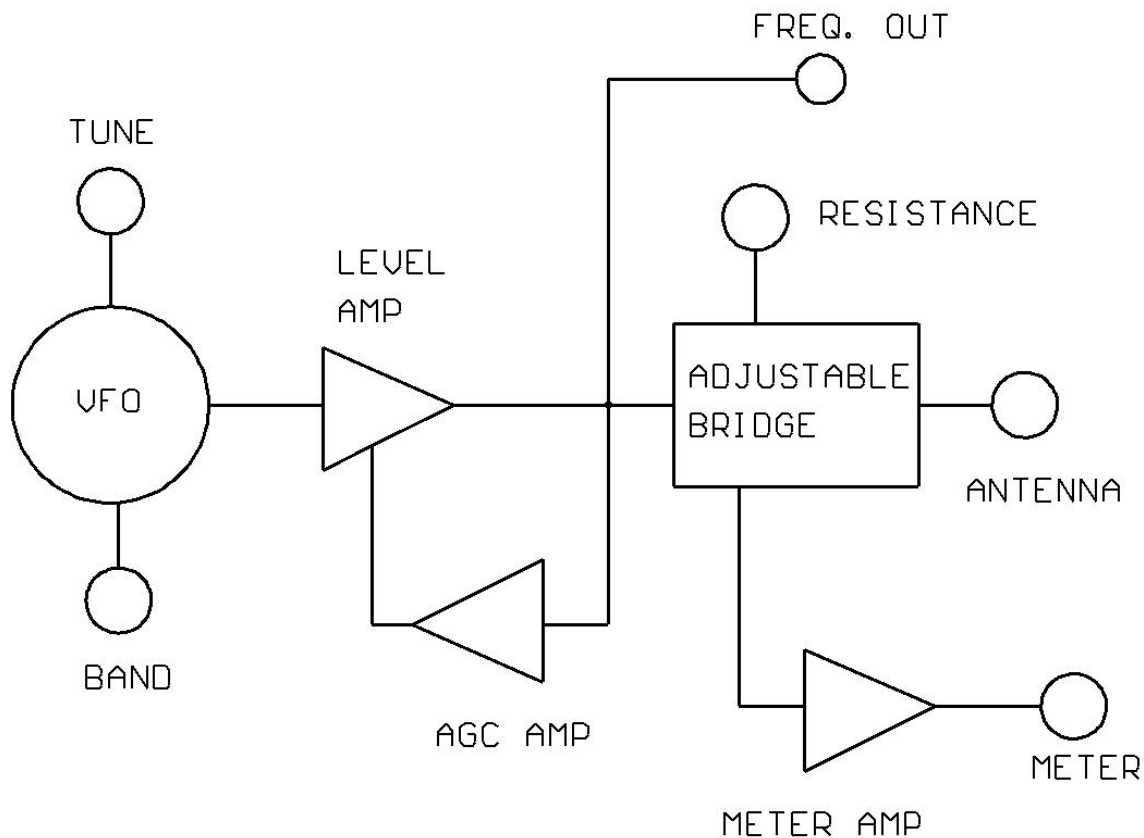

FIGURE 2: End Panel Jacks

1. **ANTENNA:** This SO-239 Antenna connector allows you to easily hook up your station's antenna to the MFJ-204B.
2. **FREQ. OUT:** For additional accuracy you can hook up a frequency counter to this phono connector or feed the signal over a short piece of wire to your radio and zero beat against your radio as described in Appendix A.
3. **PWR:** This 2.1 mm jack allows you to attach a MFJ-1312D AC adapter or feed power from your station supply.

Block Diagram**FIGURE 3: Block Diagram**

Refer to Figure 3 and the Schematic diagram Figure 5 for this discussion of the theory of operation. RF is developed in the VCO consisting of L1 through L10 and the associated FETs Q1 and Q2 along with the variable capacitor. The Band Switch progressively shorts out the inductors as the frequency range is increased. The RF is then passed to Q3 and amplified. This RF is sensed by D2 and the resulting voltage is fed to U2 where it is amplified and fed to Q4. Q4 varies the voltage on the source of Q1 and Q2 maintaining the stable RF level. The RF then goes to the bridge consisting of two fixed legs and one variable leg the RESISTANCE Pot. The 4th leg of the bridge is the unknown leg which is the Antenna input to the unit. When the bridge is unbalanced then D1 rectifies the unbalanced voltage and this is amplified by U2 and deflects the meter. When the 4 legs are

Easy Start Instruction

The MFJ-204B requires the optional MFJ-1312D power supply adapter or a nine-volt transistor battery. If using a battery with the MFJ-204B ensure it is an ALKALINE nine-volt battery. Additionally you can use a 13.8 volt power supply by connecting a 2.1 mm plug to the cable with the positive wire connected to the center pin and the ground wire connector to the outer pin.

To install the battery, remove the screws holding the cover onto the case. Insert the battery into the battery holder. Tuck the battery snap wires out of the way so they do not interfere with the tuning capacitor rotation. Reinstall the cover and screws.

I. How to measure the antenna impedance at the antenna feed point.

1. Turn on the MFJ-204B
2. Attach the MFJ-204B to the antenna as close to the feed point using the Shortest length of RG-58U or RG-8U that you can.
3. Set the BAND switch to the appropriate band.
4. Adjust the FREQUENCY DIAL of the ANTENNA BRIDGE to the frequency at which you want to check the SWR. For added accuracy connect a frequency counter to the Freq. Out jack or zero beat against your receiver as described in Appendix A.
5. Turn the Resistance control until a maximum dip on the meter can be achieved. Note that a complete dip to "0" on the meter may not be possible. In any case try to obtain the minimum meter reading.
6. Read the antenna resistance on the Resistance control.

II. Adjusting the antenna for resonant frequency.

1. Follow the steps from 1 thru 6 on section I.
2. If the resistance does not read 50 ohms, set the Resistance control to 50 ohms.
3. Adjust your antenna until the meter of the MFJ-204B reads minimum. At this point the feed point impedance of the antenna is 50 Ohms at the frequency which was selected.

HINT: If you are adjusting an antenna for the first time, it is recommended that you start with elements a little too long, then shorten to resonance. Again the Null for your particular antenna may never go to "0". Always adjust for the lowest reading.

III. Using the MFJ-204B to adjust an antenna tuner.

1. Turn on the MFJ-204B
2. Attach the MFJ-204B to the tuner using the shortest length of RG-58U or RG-8U that you can.
3. Set the BAND switch to the appropriate band.
4. Adjust the FREQUENCY DIAL of the ANTENNA BRIDGE to the frequency at which you want to check the SWR. For added accuracy connect a frequency counter to the Freq. Out jack or zero beat against your receiver as described in Appendix A.
5. Set the Resistance control to 50 Ohms.

6. Adjust the antenna tuner until the meter on the MFJ-204B reads minimum.
7. Your antenna tuner is now set for 50 ohms at that frequency.
8. Disconnect the MFJ-204B completely and connect the transmitter to the tuner.
9. It is always best to check the settings with a SWR meter as some slight retuning might be necessary.
10. Always turn the Band switch to OFF when finished.

CAUTION

Never transmit into or through the MFJ-204B. Take the MFJ-204B completely out of line before transmitting! Damage to your MFJ-204B will result if left in line.

We recommend using the MFJ-1702 coax switch as shown in the diagram below for ease of use when changing bands.

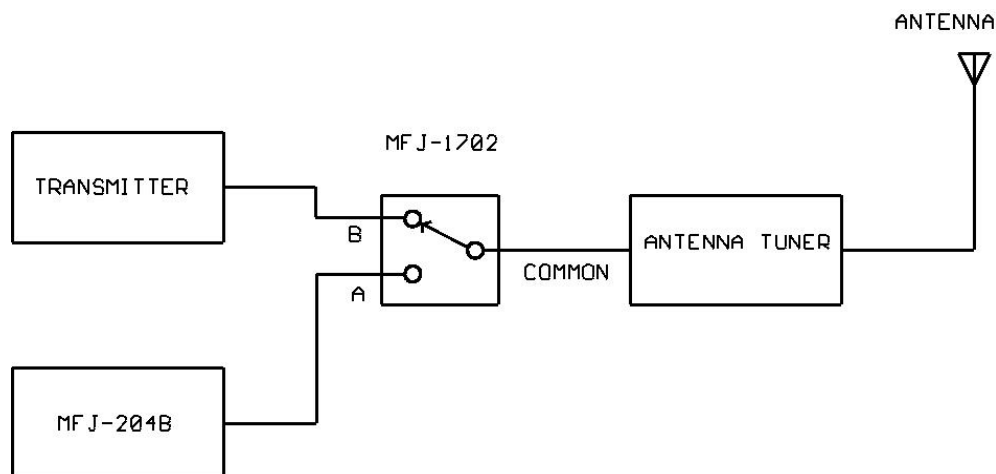

FIGURE 4: Hook-up for using the MFJ-204B to Tune Antenna

WARNING

NEVER TRANSMIT WHILE THE MFJ-1702 COAX SWITCH IS SWITCHED TO A IF THE TRANSMITTER IS CONNECTED TO B.

SERIOUS DAMAGE TO YOUR RADIO CAN OCCUR.

TRANSMIT ONLY WHEN THE COAX SWITCH IS SWITCHED TO THE CONNECTOR TO WHICH THE TRANSMITTER IS CONNECTED.

IF THE TRANSMITTER INPUT IS ON B, THEN TRANSMIT ONLY WHEN THE COAX SWITCH IS IN POSITION B.

IF THE TRANSMITTER INPUT IS ON A, THEN TRANSMIT ONLY WHEN THE COAX SWITCH IS IN POSITION A.

THE CENTER CONDUCTOR OF THE UNSELECTED COAX POSITION IS GROUNDED, SO TRANSMITTING INTO B WHILE THE SWITCH IS IN POSITION WILL CAUSE YOU TO TRANSMIT INTO A DEAD SHORT TO GROUND

MFJ ENTERPRISES, INC, WILL NOT BE LIABLE
FOR ANY DAMAGE TO YOUR RADIO OR
OTHER EQUIPMENT DUE TO IMPROPER
CONNECTION OR USE OF THE MFJ-1702 COAX
SWITCH

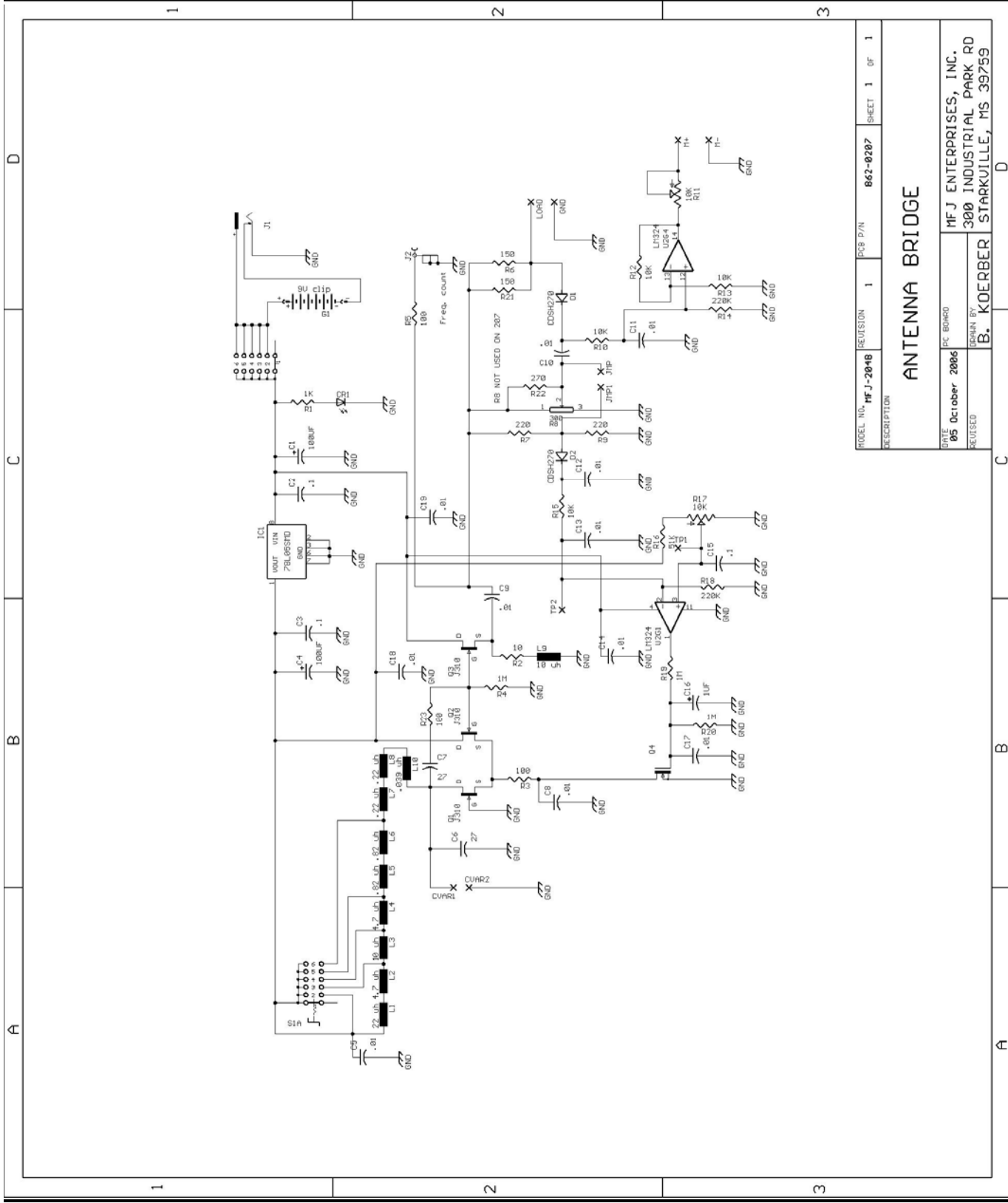

Figure 5: MFJ-204B Schematic Diagram

HOW TO ZERO BEAT THE MFJ-204B AGAINST THE RECEIVER

The Freq. Out jack on the MFJ-204B has a sine wave output which can be used to accurately check the frequency at which the MFJ-204B is adjusted to.

To zero-beat against the receiver, loosely couple a wire from the RCA jack (Freq. Out) to the antenna connector on your radio.

First, try a small length of wire from the Freq. Out connector of the MFJ-204B. Just leave it dangling free, not touching the Antenna input of the receiver. Place the far end of the wire near the receiver but do not connect it to the receiver's input unless you simply cannot hear the signal at all. The output of the MFJ-204B is a high level and damage to the front end of some radios may occur with a direct connection, so you assume all risks in making a direct connection.

Turn the radio on and tune to the frequency in question. For example, if you want to check your 40 meter dipole on 7.235 MHz, set the radio for 7.235 MHz. Turn the RF gain and the Audio of your radio down as the level of the MFJ-204B is strong. Put your radio in the CW mode. If you have a BFO adjustment on your radio, be sure to set the BFO to ON and to 0 (zero).

Set the MFJ-204B to band C. Adjust the tune dial on the MFJ-204B until you start hearing a tone in the radio's speaker. As you slowly turn the TUNE dial, the frequency will start at a very high pitch, and then decrease to zero pitch. The point where the tone goes to zero hertz is the "zero-beat". That means the MFJ-204B is set exactly to the setting on the radio.

Now make a note of where the dial is set on the MFJ-204B so you can re-set the frequency if you accidentally bump the TUNE control.

You can now disconnect the wire and re-connect the antenna to the MFJ-204B.

IN CASE OF DIFFICULTY

[] **Unit will not turn on** – Ensure you have a fresh battery in the unit or your power supply is plugged in all the way to the unit.

[] **Unit drifts excessively** – This is normally caused by low battery voltage. Replace the battery with a fresh battery.

[] **Meter never moves off full scale** – Ensure your antenna is properly connected to the unit.

TECHNICAL ASSISTANCE

If you have any problem with this unit first check the appropriate section of this manual. If the manual does not reference your problem or is your problem is not solved by reading the manual, you may call *MFJ Technical Service* at **662-323-0549** or the *MFJ Factory* at **662-323-5869**. You will be best helped if you have your unit, manual and all information on your station handy so you can answer any questions the technician may ask.

You can also send questions by mail to MFJ Enterprises, Inc., 300 Industrial Park Road, Starkville, MS 39759; by Facsimile (FAX) to 662-323-6551; or by email to techinfo@mfjenterprises.com. Send a complete description of your problem, an explanation of exactly how you are using your unit, and a complete description of your station.

FULL 12-MONTH WARRANTY

MFJ Enterprises, Inc. warrants to the original owner of this product, if manufactured by MFJ Enterprises, Inc. and purchased from an authorized dealer or directly from MFJ Enterprises, Inc. to be free from defects in material and workmanship for a period of 12 months from date of purchase provided the following terms of this warranty are satisfied.

1. The purchaser must retain the dated proof-of-purchase (bill of sale, canceled check, credit card or money order receipt, etc.) describing the product to establish the validity of the warranty claim and submit the original or machine reproduction of such proof of purchase to MFJ Enterprises, Inc. at the time of warranty service. MFJ Enterprises, Inc. shall have the discretion to deny warranty without dated proof-of-purchase. Any evidence of alteration, erasure, of forgery shall be cause to void any and all warranty terms immediately.
2. MFJ Enterprises, Inc. agrees to repair or replace at MFJ's option without charge to the original owner any defective product provided the product is returned postage prepaid to MFJ Enterprises, Inc. with a personal check, cashiers check, or money order for **\$10.00** covering postage and handling.
3. MFJ Enterprises, Inc. will supply replacement parts free of charge for any MFJ product under warranty upon request. A dated proof of purchase and a **\$8.00** personal check, cashiers check, or money order must be provided to cover postage and handling.
4. This warranty is **NOT** void for owners who attempt to repair defective units. Technical consultation is available by calling (662) 323-5869.
5. This warranty does not apply to kits sold by or manufactured by MFJ Enterprises, Inc.
6. Wired and tested PC board products are covered by this warranty provided **only the wired and tested PC board product is returned**. Wired and tested PC boards installed in the owner's cabinet or connected to switches, jacks, or cables, etc. sent to MFJ Enterprises, Inc. will be returned at the owner's expense un-repaired.
7. Under no circumstances is MFJ Enterprises, Inc. liable for consequential damages to person or property by the use of any MFJ products.
8. **Out-of-Warranty Service:** MFJ Enterprises, Inc. will repair any out-of-warranty product provided the unit is shipped prepaid. All repaired units will be shipped COD to the owner. Repair charges will be added to the COD fee unless other arrangements are made.
9. This warranty is given in lieu of any other warranty expressed or implied.
10. MFJ Enterprises, Inc. reserves the right to make changes or improvements in design or manufacture without incurring any obligation to install such changes upon any of the products previously manufactured.
11. All MFJ products to be serviced in-warranty or out-of-warranty should be addressed to **MFJ Enterprises, Inc., 300 Industrial Park Rd, Starkville, Mississippi 39759, USA** and must be accompanied by a letter describing the problem in detail along with a copy of your dated proof-of-purchase and a telephone number.
12. This warranty gives you specific rights, and you may also have other rights, which vary from state to state.